

Description

Flush-Mount, 110~230VAC for most Fan-Coil and AC – Heat/Cool applications + MODBUS RTU interface to B.M.S.

The TATC-SUPER allows users the flexibility of having one main controller for most HVAC traditional FC applications. It can be flush-mounted on wall or installed directly into the HVAC unit, and provide optional external temperature sensor input for the return air.

The TATC-SUPER has a large and easy to read backlight LCD with one tenth of a degree temperature display.

The TATC-SUPER also offers a special contact input for 1 of 4 options:

1. Auto-change over sensor, where the incoming water temperature dictates the Mode.
2. Contact input for remote switch, which changes the Mode of one or many thermostats linked together.
3. Contact input for remote switch that activates Economy mode.
4. Contact input to Turn OFF units.

Features & Benefits

- Flush-Mount, 110~230VAC, Thermostat
- Can be connected to:
 - 4 pipe system – 2 valves
 - 2 pipe system – 1 valve
- DIP switch control options:
 - Enable/Disable Auto mode
 - Normal temperature display or set point only
 - Fan on demand – always active or selectable
- 10 Hours timer to turn the unit ON or OFF
- Remote control – option
- Energy saving – cost efficient, environmental friendly
- Available in different colors

Technician configuration:

- Set point temperature limits for cool and heat
- Lock the buttons
- Offset for temperature reading calibration
- Enable/Disable LCD backlight
- Temperature scale – Celsius/Fahrenheit
- Contact input – Normally open/close
- Internal or external temperature sensor
- Economy set point for cool and heat
- Internal/External temperature sensor reading
- Beeper enable/disable option

Wiring diagrams

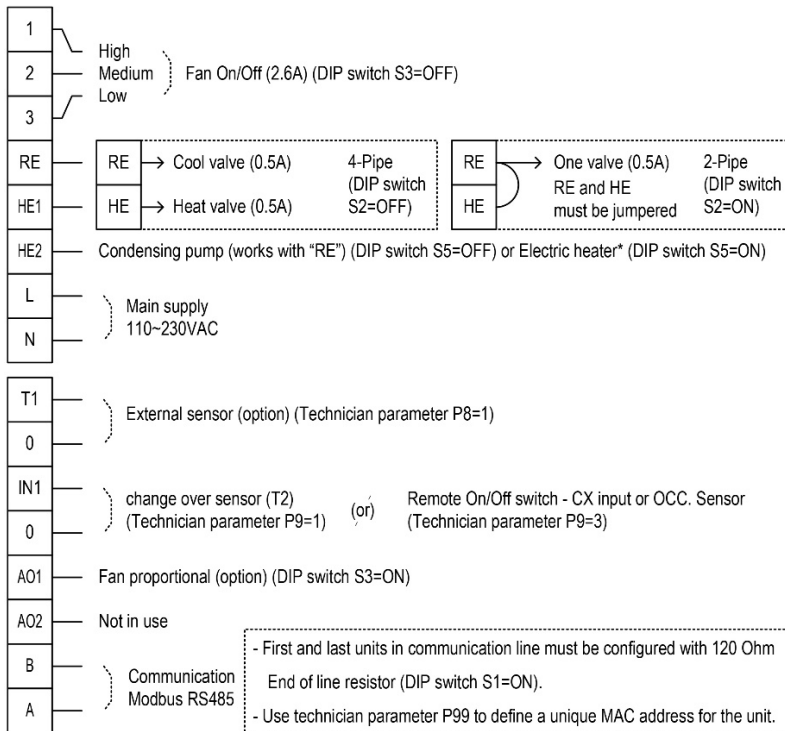

Technical specifications

- Operating voltage: 110~230VAC
- Temperature readings scale: 10°C÷30°C/50°F÷86°F
- Temperature sensor type: NTC 50K@25°C/77°F
- Operating temperature: 0°C÷50°C / 80%RH
- Storage temperature/Humidity: -10°C÷60°C / 80%RH
14°F÷140°F / 80%RH
- Plastic type: PC/ABS
- Flammability: UL94V-0

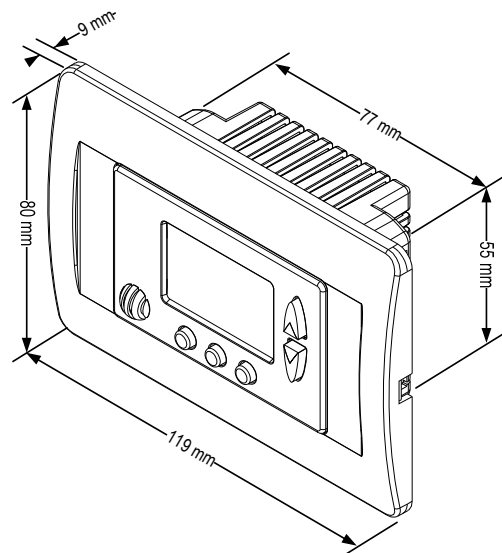

The performance specifications are nominal and conform to acceptable industry standards. For applications at conditions beyond these specifications, consult the local Meitav-tec office or representative. Meitav-tec shall not be liable for damages resulting from misapplication or misuse of its products.

This document is subject to change without any notice.

© Copyright 2020 Meitav-tec Ltd'. All rights reserved.